



SPOA7 With Movable Pads

Capacity 7,000 lbs.
(600 Series Lifts)

SPOA82

Capacity 7,000 lbs.
(600 Series Lifts)

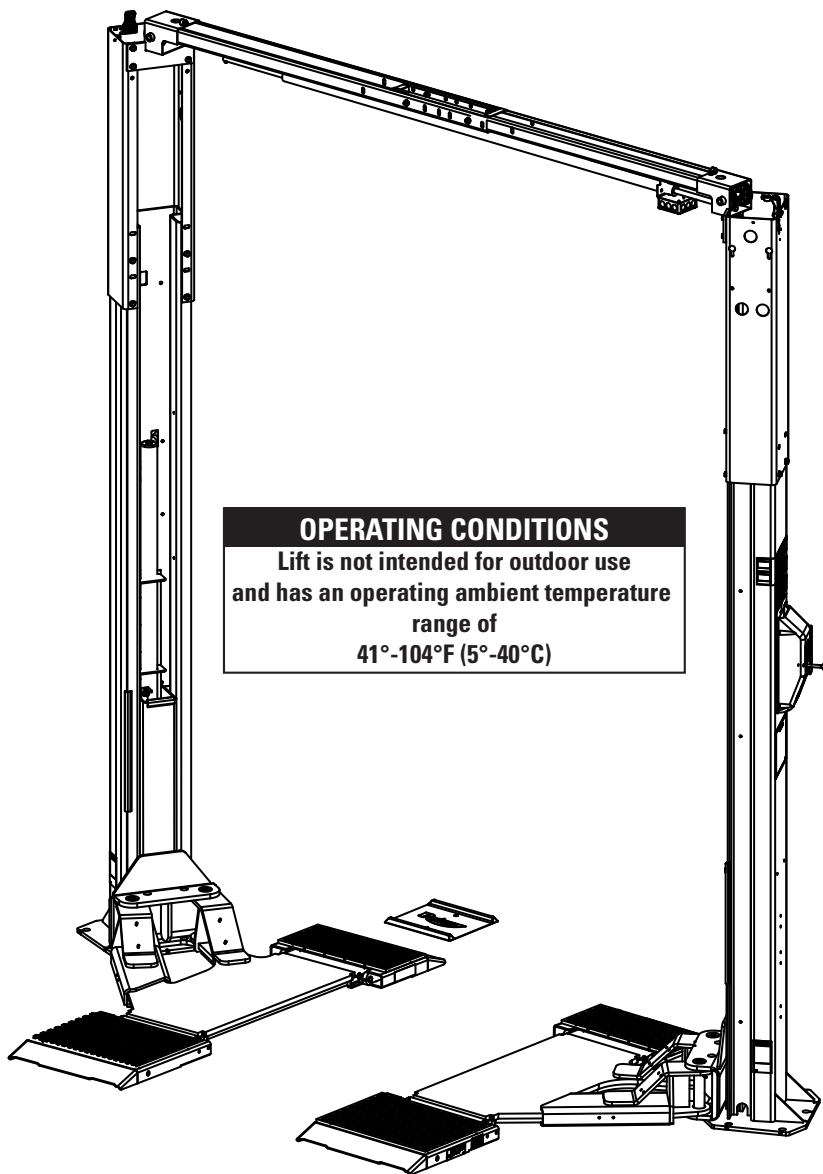

**I
N
S
T
A
L
L
A
T
I
O
N

I
N
S
T
R
U
C
T
I
O
N
S**

1. Lift Location: Use architects plan when available to locate lift. Fig. 1a shows dimensions of a typical bay layout.

2. Lift Height: See Fig. 5 for overall lift height of each specific lift model. Add 1" min. to overall height to lowest obstruction.

⚠ WARNING DO NOT install this lift in a pit or depression due to fire or explosion risks.

IMPORTANT Floor slope for should not exceed 1/16 per foot for pad lifts.

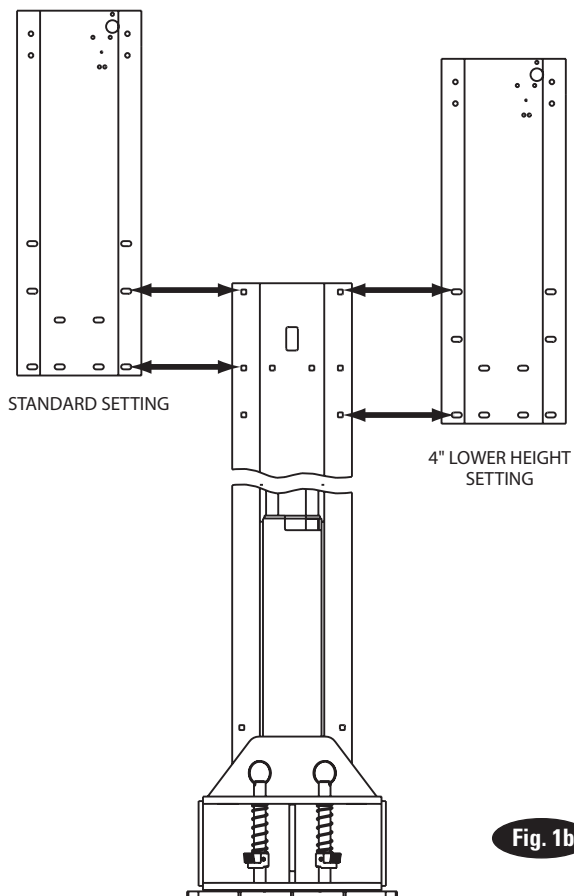
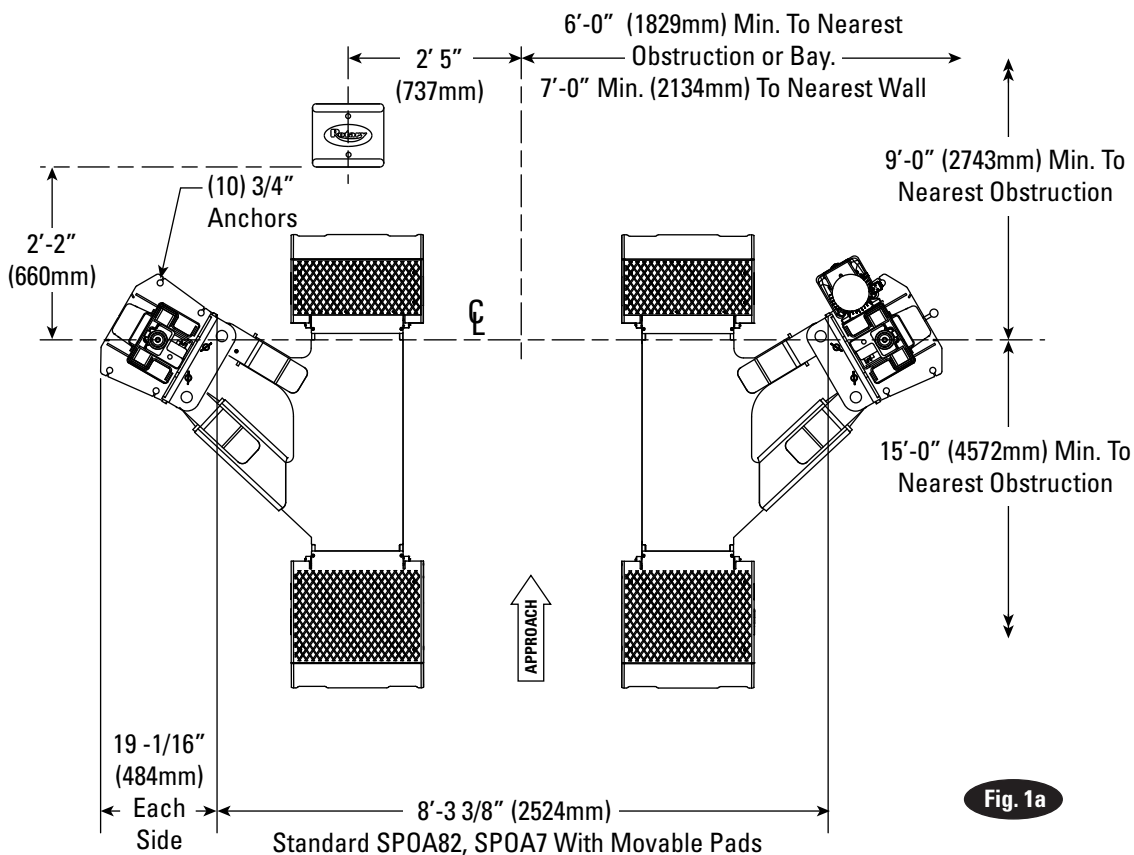

3. Column Extensions: Before standing columns upright, install the column extensions using (12) 3/8"-16NC x 3/4" Carriage HHCS and Flanged Locknuts, Fig. 3. Note which holes in column and extension to use, Fig. 1b.

4. Latch Cable Guides: Install the latch cable conduit guide brackets to column extensions with (1) 1/4"-20NC x 1" HHCS and 1/4"-20NC Flanged Locknuts, Fig. 2. HHCS should go through hole nearest the edge as shown, Fig. 2.

5. Overhead Mounting Bracket: Install Mounting Brackets to column extensions as shown, Fig. 3.

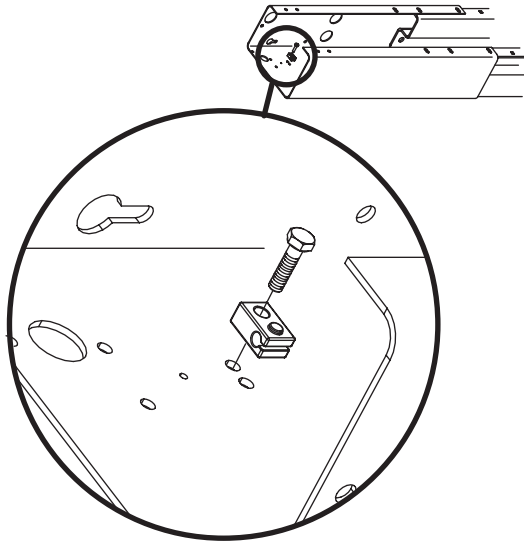

Fig. 2

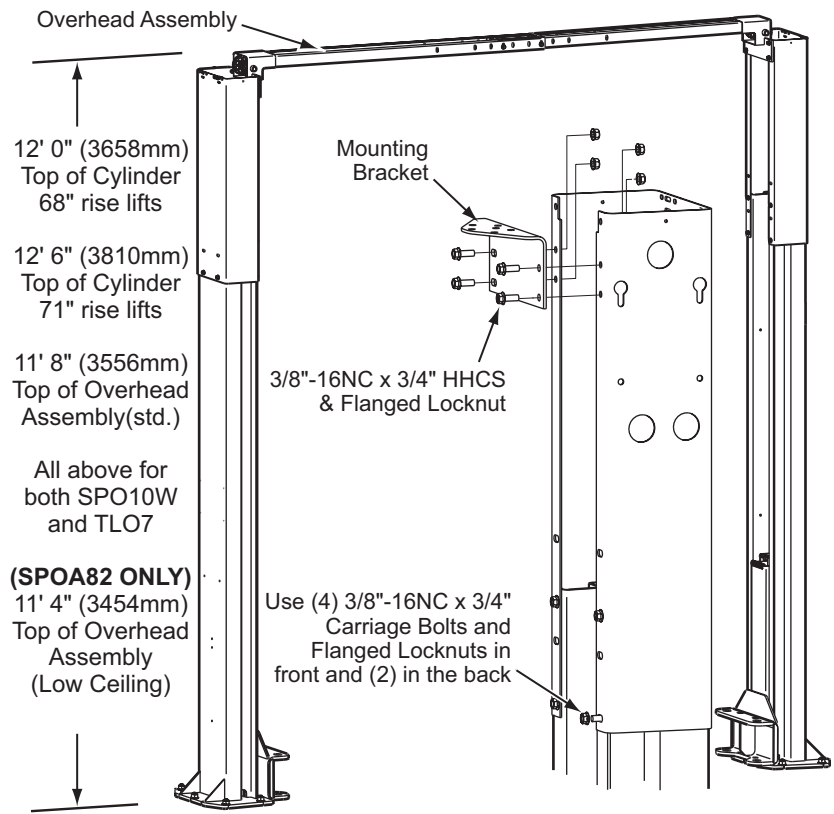

Fig. 3

6a. Lift Setting: Position columns in bay using dimensions shown in Fig. 1a. Place column with power unit mounting bracket as shown in Fig. 1a. Both column base plate backs must be square on center line of lift. Notches are cut into each base plate to indicate center line of lift.

6b. Using appropriate equipment, raise carriage to first latch position. Be sure locking latch is securely engaged. Install one anchor bolt as indicated in Figure 4b per instructions in step 7.

6c. Superstructure: Raise carriage to a convenient height. Assemble the rear arm first. The superstructure and welded arm are mounted next. Then slide the superstructure into rear arm. The ends of the arms should be parallel with the inside edge of the pad. Insert arm pins, see Fig. 4a. Attach arm pin tops to yoke using 5/16"-18NC x 1-1/4" LG. HHCS, 5/16" fender washers, and 5/16"-18NC Nyloc lock nut through restraint actuator pin holes.

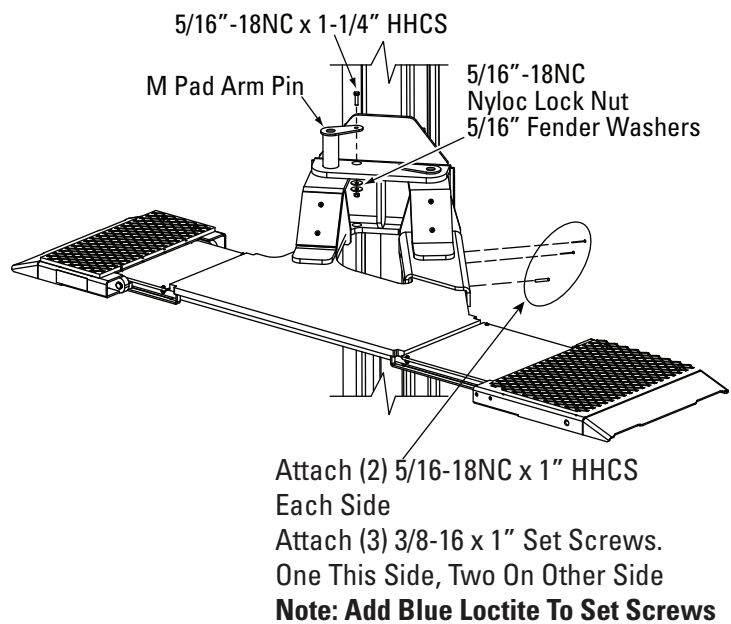

Fig. 4a

NOTE: Right side shown, Fig. 4a, left hand side pad assembled just opposite.

6d. Aligning Pads: With pads installed, measure the inside distance between the front end of the pads and the rear end of the pads. If they are not equal, pivot the pad structure slightly to achieve parallel pads. Be sure pads are parallel and in line front to rear, Fig. 4b. Install (2) 5/16-18NC x 1" HHCS into rear arm and torque to 17 ft-lb. Install (3) 3/8-16 x 1" set screws (adding blue Loctite) into the rear arm and tighten to 25 ft-lb. If the pads cannot be completely aligned using the bolts and set screws, the column(s) can be rotated slightly by loosening the anchor bolt nut.

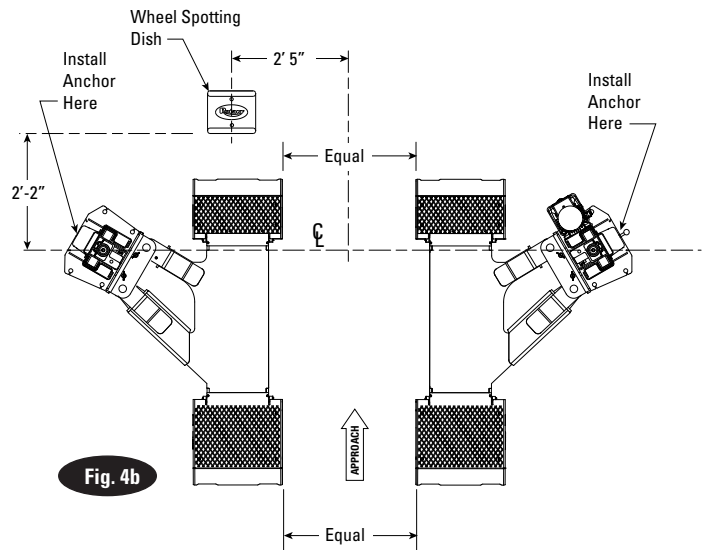

Fig. 4b

NOTE: During the installation of the anchors mount retaining brackets (two per column) as shown below. Option #1 is mounted on the back sides of the columns. Option #2 is mounted on the sides of the columns.

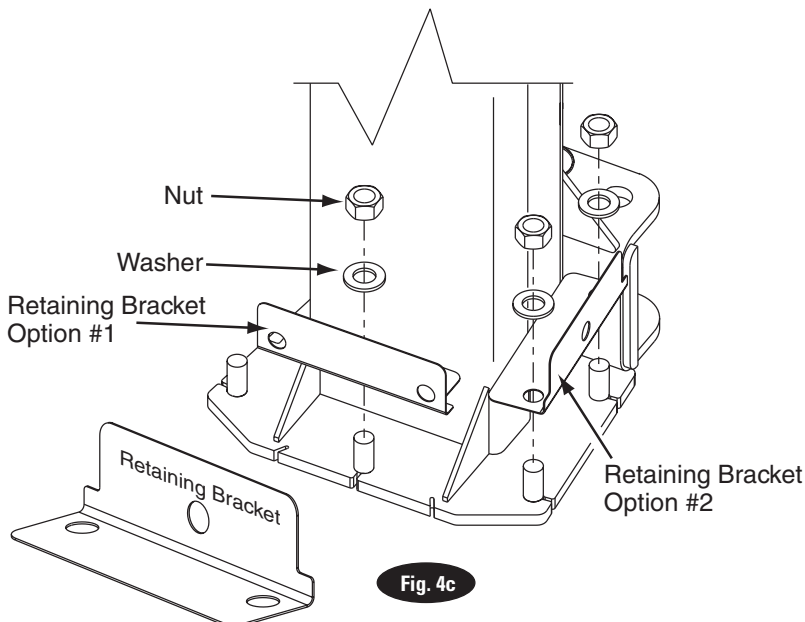

Fig. 4c

7. Concrete Requirements:

Drill (10) 3/4" dia. holes in concrete floor using holes in column base plate as a guide. See Fig. 5a and Fig. 5b for hole depth, hole spacing, and edge distance requirements.

CAUTION DO NOT install on asphalt or other similar unstable surfaces. Columns are supported only by anchors in floor.

IMPORTANT Using the horse shoe shims provided, shim each column base until each column is plumb. If one column has to be elevated to match the plane of the other column, full size base shim plates should be used (Reference FA5112 Shim Kit). Recheck columns for plumb. Tighten anchor bolts to an installation torque of 110 ft.-lbs. Shim thickness MUST NOT exceed 1/2" when using the 5-1/2" long anchors provided with the lift, Fig. 5c. Adjust the column extensions plumb.

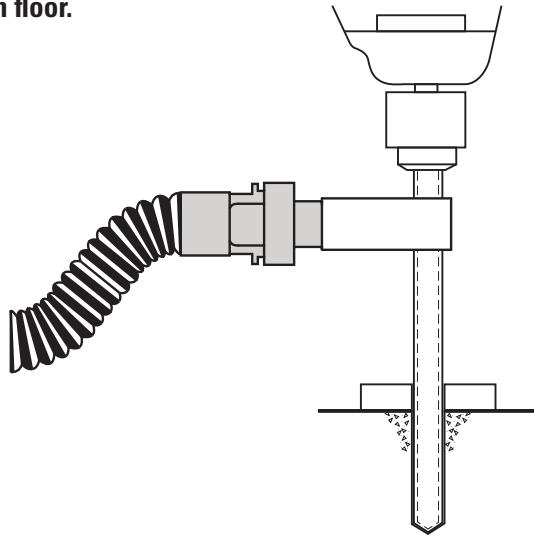
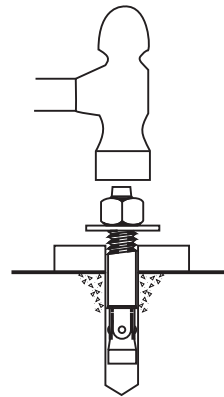
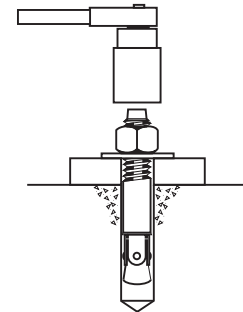

Fig. 5a

Drill holes using 3/4" carbide tipped masonry drill bit per ANSI B212.15-1994 (R2000). Construction dust collected per OSHA 29 CFR 1926.1153.



Run nut down just below impact section of bolt. Drive anchor into hole until nut and washer contact base.



Tighten nut with Torque wrench to 110 ft.-lbs. (149 Nm).

CONCRETE AND ANCHORING REQUIREMENTS				
STANDARD	ANSI/ALI ALCTV	IBC 2006, 2009, 2012		SEISMIC
Minimum Floor Thickness	4-1/4 INCHES	5 INCHES	6 INCHES	Varies by location consult with your structural engineer and manufacturer's representative.
Anchor	Hilti Kwik Bolt III 3/4" x 5-1/2" Anchors supplied with the lift.*	Hilti HIT-HY 150 MAX-SD Adhesive; Hilti HIT-HY 150 MAX Adhesive; HILTI HIT-RE 500-SD Adhesive	Hilti Kwik Bolt III 3/4" x 7"	
Minimum Concrete Strength	3000 PSI	3000 PSI	3000 PSI	
Minimum Anchor Embedment	3-1/4 INCHES	3-1/2 INCHES	3-3/4 INCHES	
Minimum Distance to Concrete Edge, Crack, Expansion Joint, Abandoned Anchor Hole	4-1/2 INCHES	5-1/4 INCHES	3-1/4 INCHES	
<p>*The supplied concrete fasteners meet the criteria of the American National Standard "Automotive Lifts - Safety Requirements for Construction, Testing, and Validation" ANSI/ALI ALCTV-2011, and the lift owner is responsible for all charges related to any additional anchoring requirements as specified by local codes. Contact customer service for further information at: 800.445.5438</p>				

Fig. 5b

If anchors do not tighten to 110 ft-lbs. installation torque, replace concrete under each column base with a 4' x 4' x 6" thick 3000 PSI minimum concrete pad keyed under and flush with the top of existing floor. Let concrete cure before installing lifts and anchors.

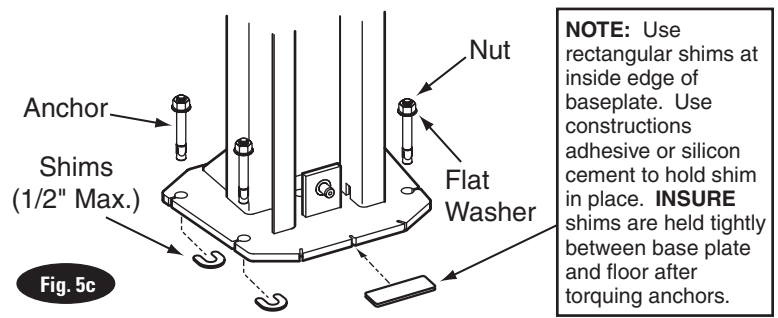

NOTE: Use rectangular shims at inside edge of baseplate. Use construction adhesive or silicon cement to hold shim in place. **INSURE** shims are held tightly between base plate and floor after torquing anchors.

NOTE: If more than 2 horse shoe shims are used at any of the column anchor bolts, pack non-shrink grout under the unsupported area of the column base. Insure shims are held tightly between the baseplate and floor after torquing anchors.

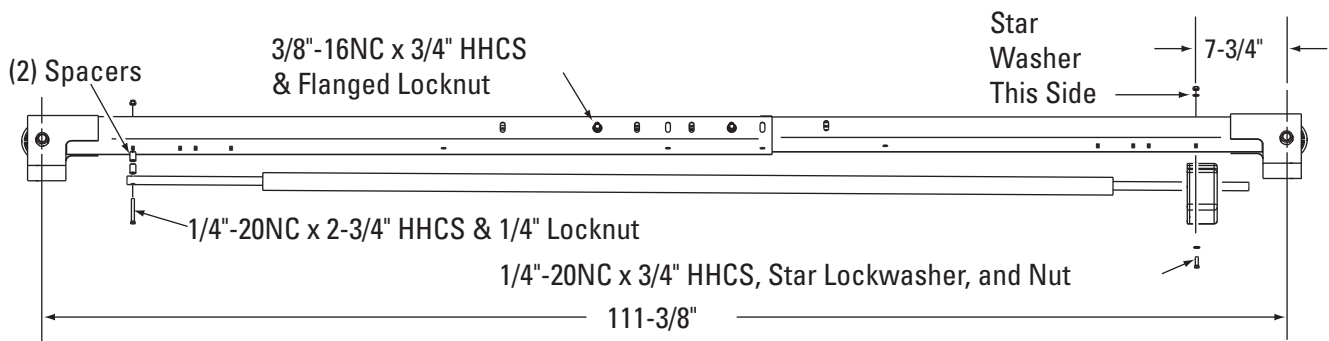
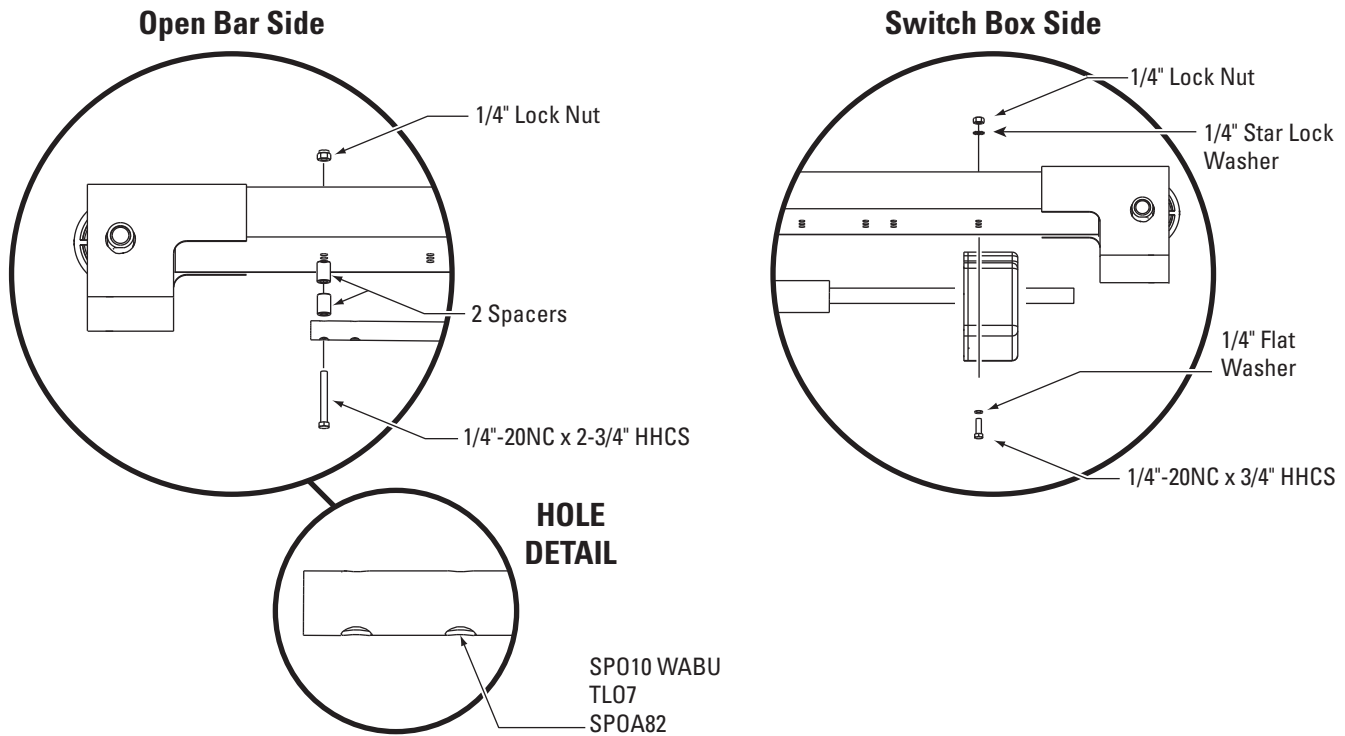

Fig. 6

Hardware Detail For Overhead Assembly



8. Overhead Assembly: Fig. 6: Adjust overhead to appropriate dimension. Install (4) 3/8"-16NC x 3/4" HHCS & 3/8"-16NC Flanged Locknuts, do not tighten. Slide Switch Box over switch bar ensuring knock out holes face the power unit column. Use (2) 1/4"-20NC x 3/4" lg. HHCS, 1/4" Flat Washers, 1/4"-20NC Nuts and 1/4" Star Washers to mount switch box to overhead, see Fig. 7.

For single phase and three phase lifts with push button control box: Insert 1/4"-20NC x 2-3/4" HHCS through pivot hole in end of switch bar. Insert opposite end of bar through slot in switch mounting bracket. Then secure HHCS and Switch Bar to overhead as shown, Fig. 6, using (2) 3/4" spacers and 1/4"-20NC Locknut. Tighten Hex bolt leaving 1/16" gap between the spacer and the overhead assembly.

9. Overhead Installation: Install overhead assembly to Mounting Bracket with (2) 3/8"-16NC x 3/4" Flanged HHCS, & (2) 3/8"-16NC Flanged Locknut, Fig. 9. Use outside holes (marked L for Left and R for Right) for SPOA82. Tighten bolts at center of overhead assembly.

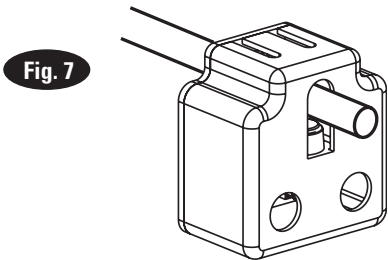

Fig. 7

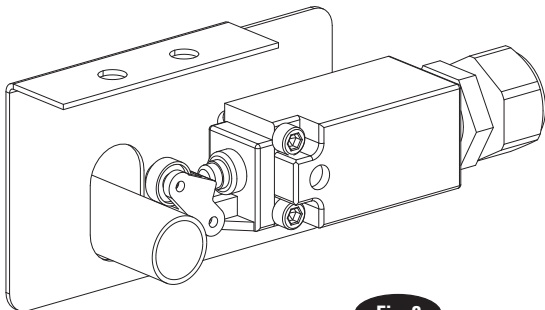

Fig. 8

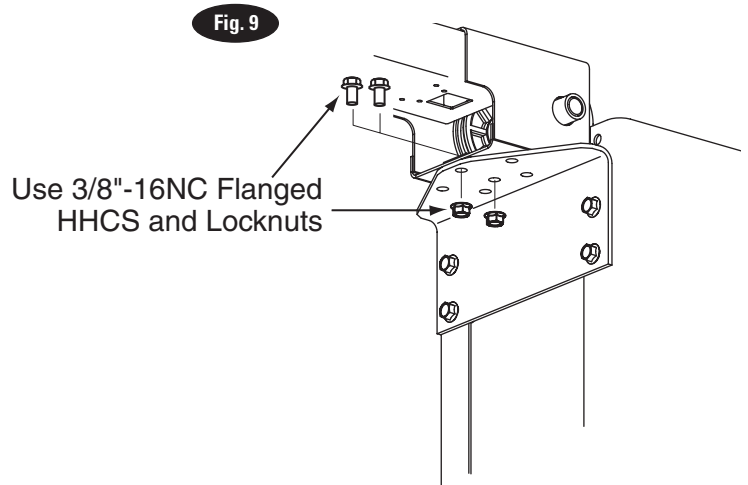
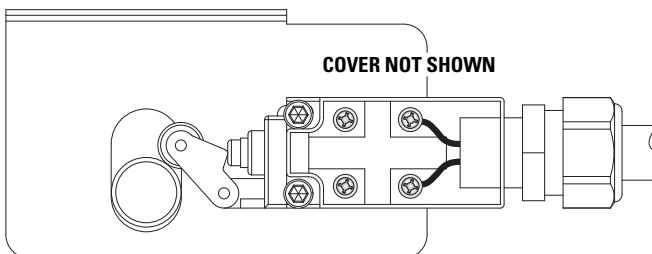

Fig. 9

Use 3/8"-16NC Flanged HHCS and Locknuts

10. Power Unit: Put the (4) 5/16"-18NC x 1-1/2" flanged locking HHCS thru holes in power unit bracket using Push-Nuts to hold in place, Fig. 8a. Mount unit with motor up to column bracket and install (2) 5/16" Flanged locking Nuts. Install and hand tighten Branch Tee to pump until O-ring is seated. Continue to tighten the locknut to 10-15 ft-lbs., or until the nut and washer bottom out against the pump manifold. **NOTE:** You may still be able to rotate the Branch Tee. This is acceptable unless there is seepage at the O-ring. If so, slightly tighten the locknut.

CAUTION Over tightening locknut may tear O-ring or distort threads in pump manifold outlet.

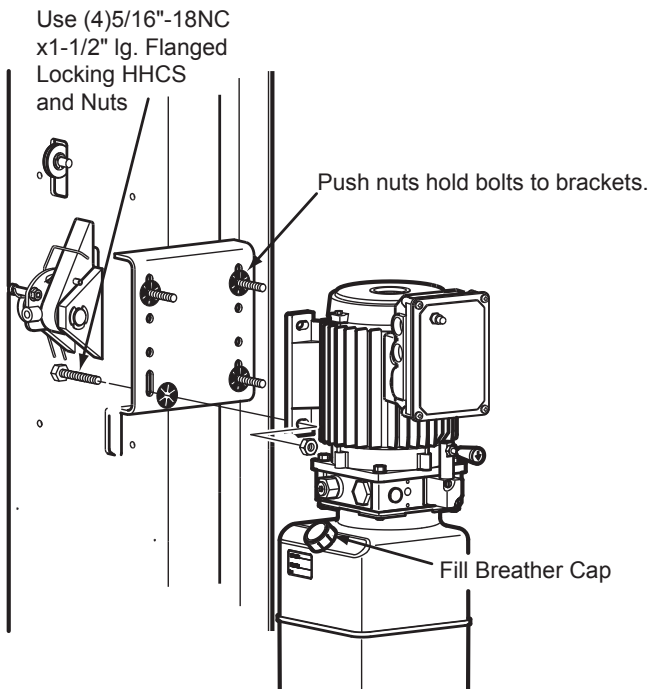

Fig. 10

11. Hoses: Clean adapters and hose. Inspect all threads for damage and hose ends to be sure they are crimped, Fig. 11. Install hose and hose clamps, Fig. 12 & Fig. 16.

Flared Fittings Tightening Procedure

1. Screw the fittings together finger tight. Then, using the proper size wrench, rotate the fitting 2-1/2 hex flats.

IMPORTANT Flare seat **MUST NOT** rotate when tightening. Only the nut should turn.

2. Back the fitting off one full turn.
3. Again tighten the fittings finger tight; then using a wrench, rotate the fitting 2-1/2 hex flats. This will complete the tightening procedure and develop a pressure tight seal.

CAUTION Overtightening will damage fitting resulting in fluid leakage.

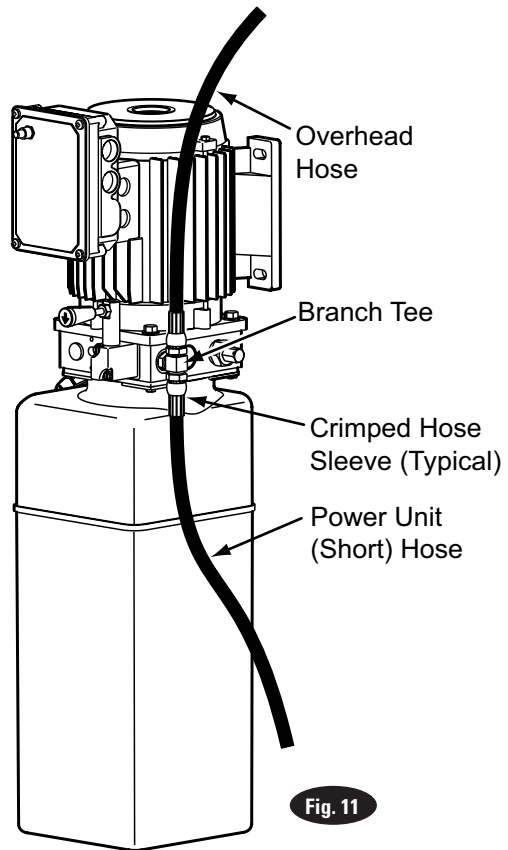
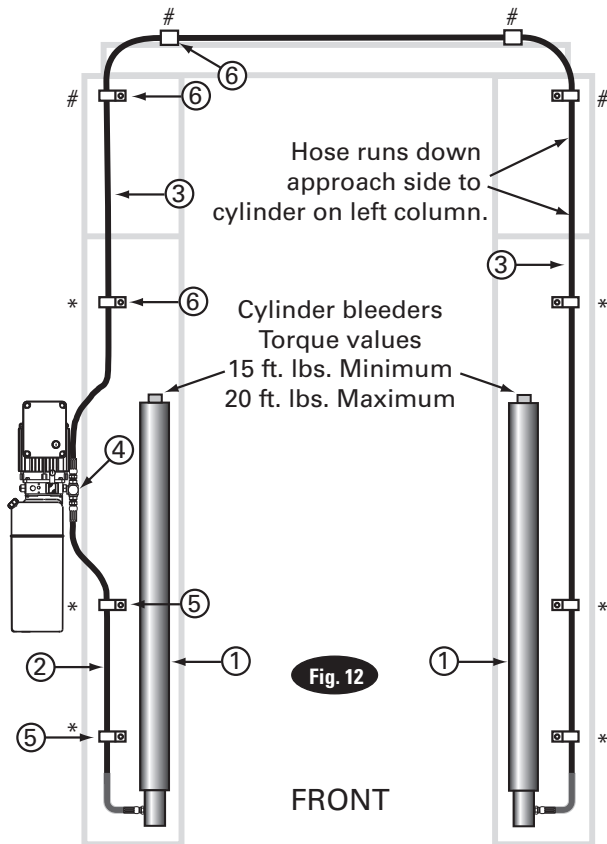

Fig. 11

Adapter & Hose Installation (see Fig. 12)

1. Install Pc. (2) with metal hose clamps, on power unit column side connecting it to the cylinder (1) first.
2. Install Pc. (3) with plastic hose clamps starting at opposite column cylinder (1) and working toward the power unit column. All excess hose should be at bends & inside overhead assembly.
3. Install Pc. (4) into power unit.
4. Connect Pc. (2) & Pc. (3) to Tee (4).

NOTE: Route Power Unit hose inside columns using slots provided at column base, Fig. 14. Route Overhead Hose in column channel on outside of column, Fig. 14. Overhead hose goes over top end of overhead assembly, Fig. 12 & Fig. 16.



ITEM	QTY.	DESCRIPTION
1	2	Hydraulic Cylinder
2	1	Power Unit Hose
3	1	Overhead Hose
4	1	Branch Tee
5	2	Metal Hose Clips
6	8	Plastic Hose Clips
*6		3/8"-16NC x 3/4" lg. Carriage Bolts
*6		3/8"-16NC Flanged Locknuts
#4		3/8"-16NC x 3/4" lg. Flanged HHCS
#4		3/8"-16NC Flanged Locknuts

12. Equalizing Cables

- A) Refer to Fig. 13 for the general cable arrangement. First, run a cable end up through the small hole in the lower tie-off plate. Fig. 15.
- B) Push the cable up until the stud is out of the carriage top opening.
- C) Run a nylon insert locknut onto the cable stud so 1/2" (13mm) of the stud extends out of the locknut.
- D) Pull the cable back down, Fig. 15.
- E) Run cable around the lower sheave, then up and around overhead sheave and across and down to the opposite carriage, Fig. 13. Install sheave cover, Fig. 14.
- F) Fasten the cable end to the carriage upper tie-off bracket, Fig. 15. Tighten the locknut enough to apply light tension to the cable.
- G) Repeat procedure for the second cable. Complete lift assembly. Adjust the tension of both cables during the final adjustments in Paragraph 23.

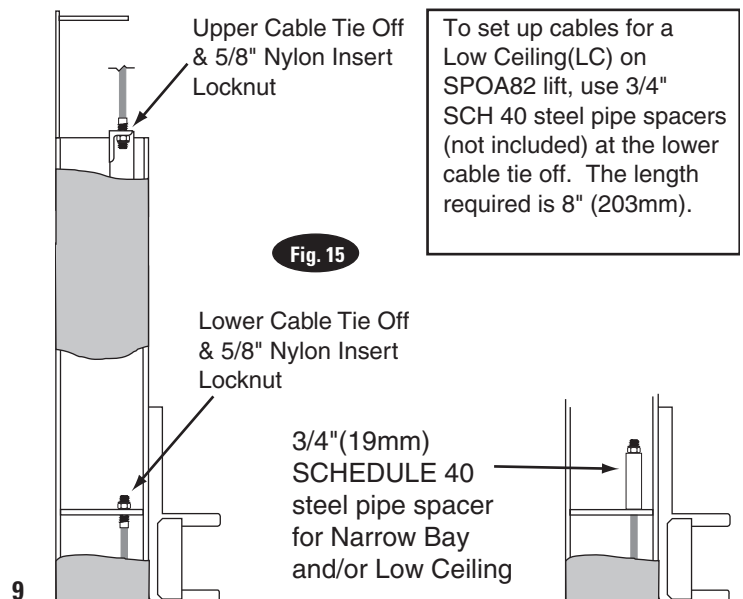
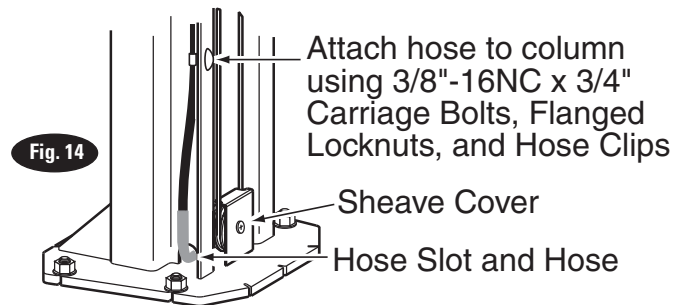
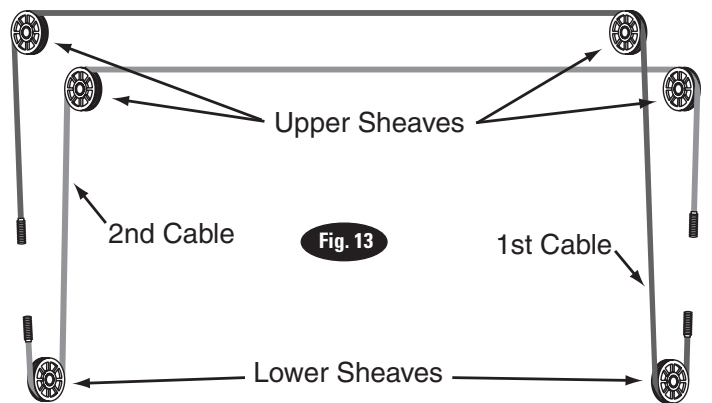

13. Locking Latch Cable

- A) Install latch cable sheave and retaining rings in upper slot of power unit column as shown, Fig. 17.
- B) Slip loop end of cable over end of shoulder screw on right side latch control plate, Fig. 17.
- C) Feed the other end of the cable through the latch cable sheave slot making sure that the cable is running under the bottom side of the latch cable sheave and inside the right column, Fig. 17.
- D) Attach latch cable conduit guide brackets to overhead as shown, Fig. 16a & Fig. 16b. Always use the holes on the approach side of the lift. HHCS should be in hole nearest the center of the overhead, Fig. 16b.
- E) Route cable up inside column and through the latch cable guide, Fig. 16a & Fig. 18.

IMPORTANT Using wire ties provided, tie off cable guide to column extension as shown, Fig. 16a. Guide must be attached in hole closest to the outside edge of the column on the NON-APPROACH side.

- F) Continue routing cable to the left column latch cable guide, Fig. 16a & Fig. 18, routing the cable through the left column latch cable guide, Fig. 16a.

IMPORTANT Using wire ties provided, tie off cable guide to column extension as shown, Fig. 16a. Guide must be attached in hole closest to the outside edge of the column on the NON-APPROACH side.

- G) Bring the cable down inside the left column and feed the end of the cable through the lower latch cable sheave slot so that the cable is now back outside the column, Fig. 19.

- H) Install latch cable sheave and retaining rings in lower slot of non-power unit column as shown, Fig. 19.

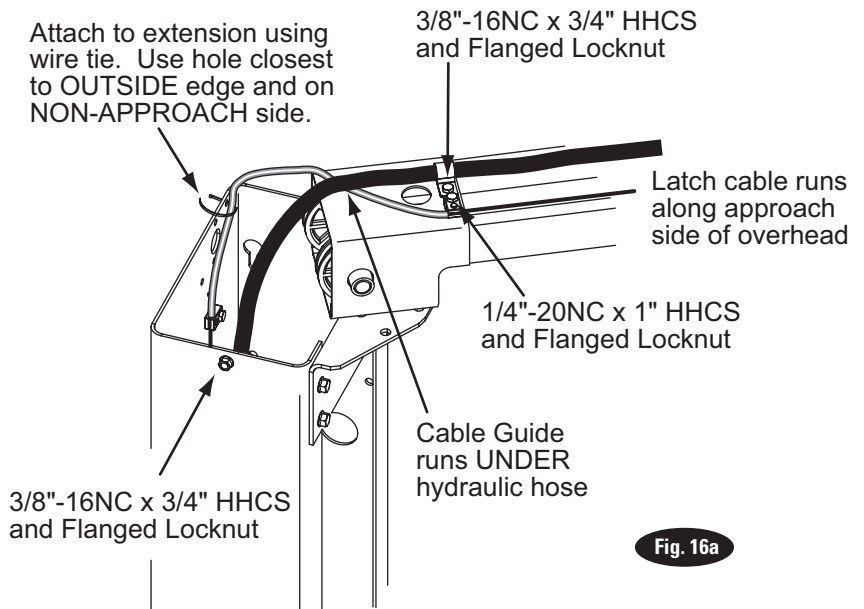

Fig. 16a

- I) Route cable under the bottom side of the latch cable sheave, Fig. 19.
- J) At this point you **MUST** install the latch handle, jam nut, and right column latch cover Fig. 17 & Fig. 20. Install latch handle ball, Fig. 20.
- K) Insert cable in cable clamp along one side, loop around shoulder screw and back down, inserting cable along other side of cable clamp, Fig. 19. Place top back on clamp, barely tightening.
- L) Next, pull the control plate down, Fig. 18 & Fig. 19, to eliminate any clearance between the control plate slot and the latch dog pin, Fig. 18.
- M) Using Pliers, pull cable tight and secure the clamp close to the shoulder screw. Tighten clamp.

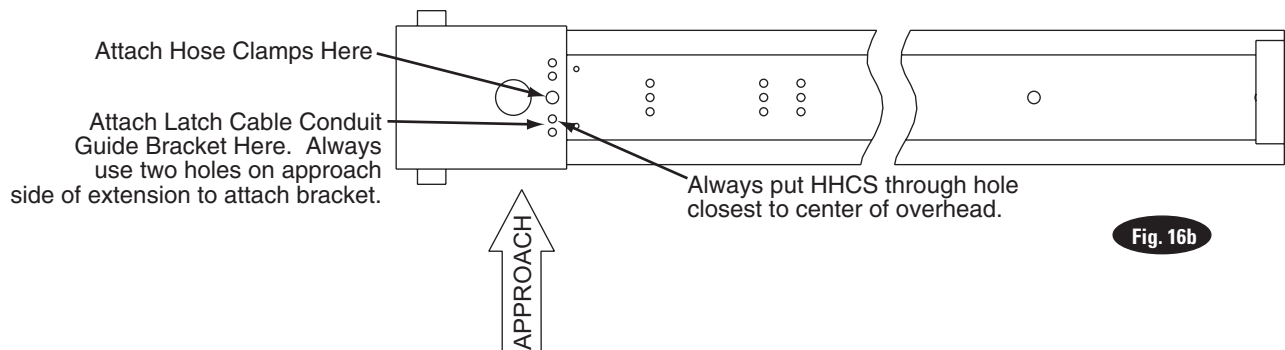

Fig. 16b

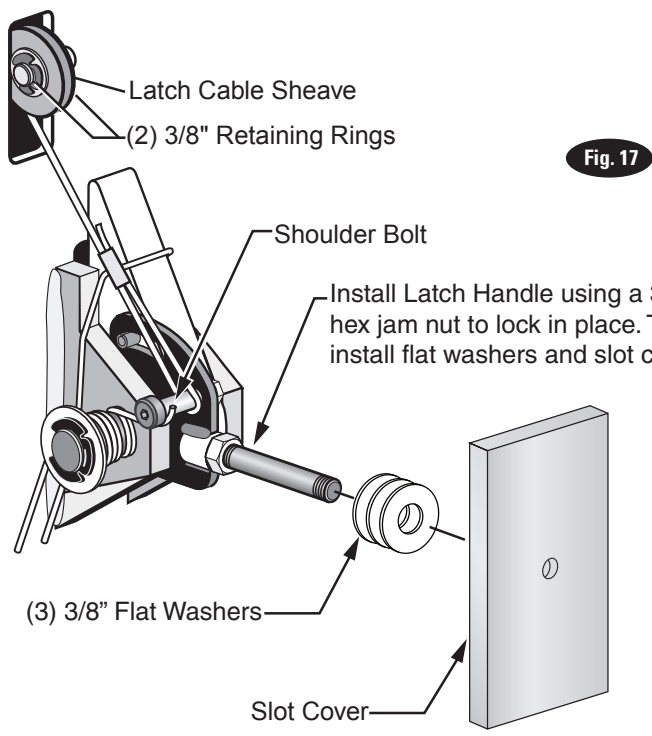

Fig. 17

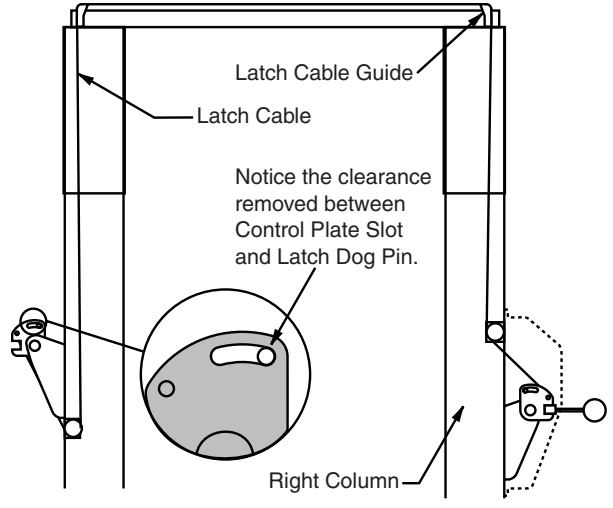

Fig. 18

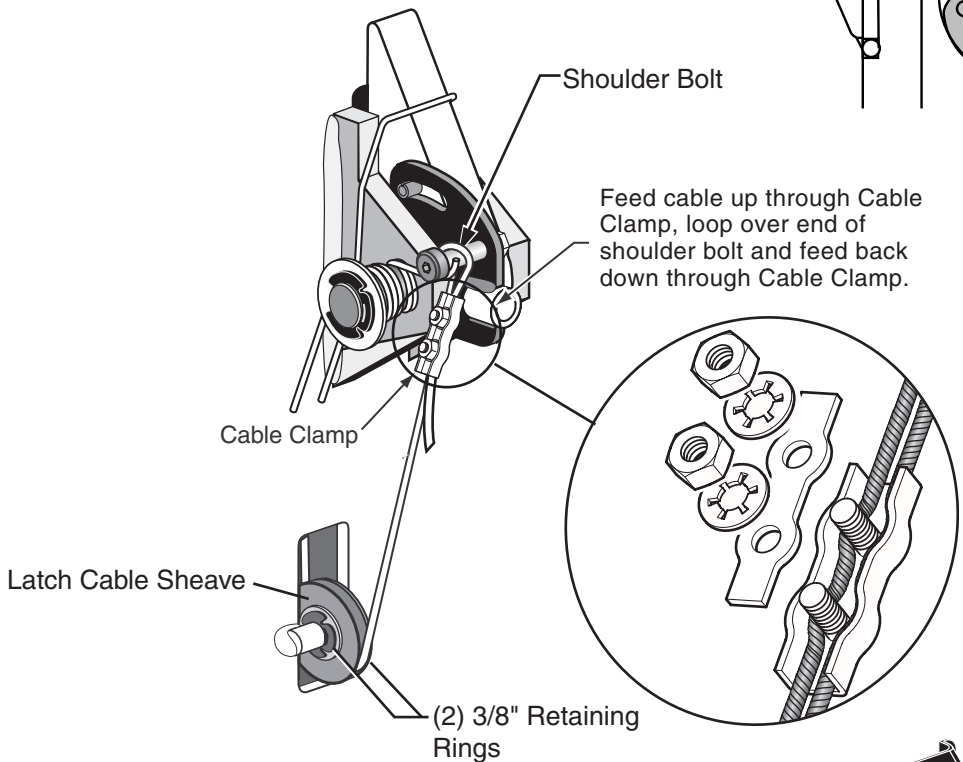

Fig. 19

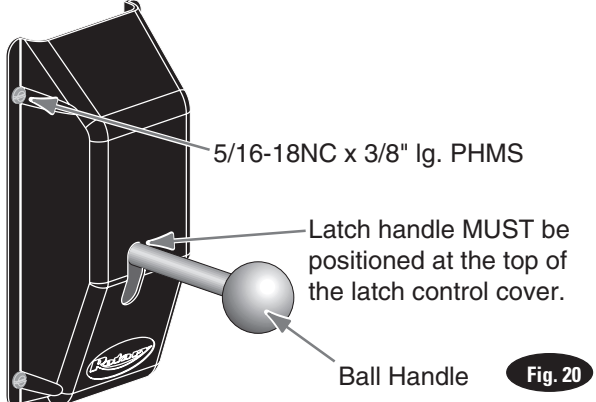

Fig. 20

14. Electrical: Have a certified electrician run appropriate power supply to motor, Fig. 21 & 23. Size wire for 20 amp circuit. See Motor Operating Data Table.

CAUTION Never operate the motor on line voltage less than 208V. Motor damage may occur.

IMPORTANT: Use separate circuit for each power unit. Protect each circuit with time delay fuse or circuit breaker. For single phase 208-230V, use 20 amp fuse. Three phase 208-240V, use 20 amp fuse. For three phase 400V and above, use 10 amp fuse. For wiring see Fig. 21, Fig. 22, and Fig. 22b. All wiring must comply with NEC and all local electrical codes.

Note: 60Hz. single phase motor **CAN NOT** be run on 50Hz. line without a physical change in the motor.

Single Phase Power Unit

MOTOR OPERATING DATA TABLE - SINGLE PHASE	
LINE VOLTAGE	RUNNING MOTOR VOLTAGE RANGE
208-230V 50Hz.	197-253V
208-230V 60Hz.	197-253V

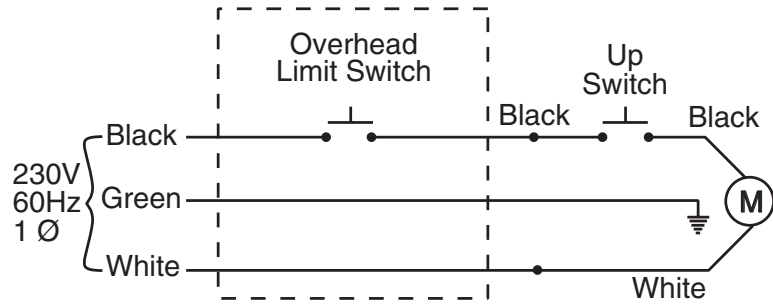

Note: 60Hz. Single phase motor **CAN NOT** be run on 50Hz. line without a physical change in the motor.

NOTE: Assure cord used for connection between the overhead switch and power unit is of the type specified in:

UL201, Sections 10.1.1.3 & 10.1.1.4

(Example: SO, G, STO) Size for 25 amp circuit. See UL 201, Section 15 for proper wiring requirements for this connection.

Fig. 21

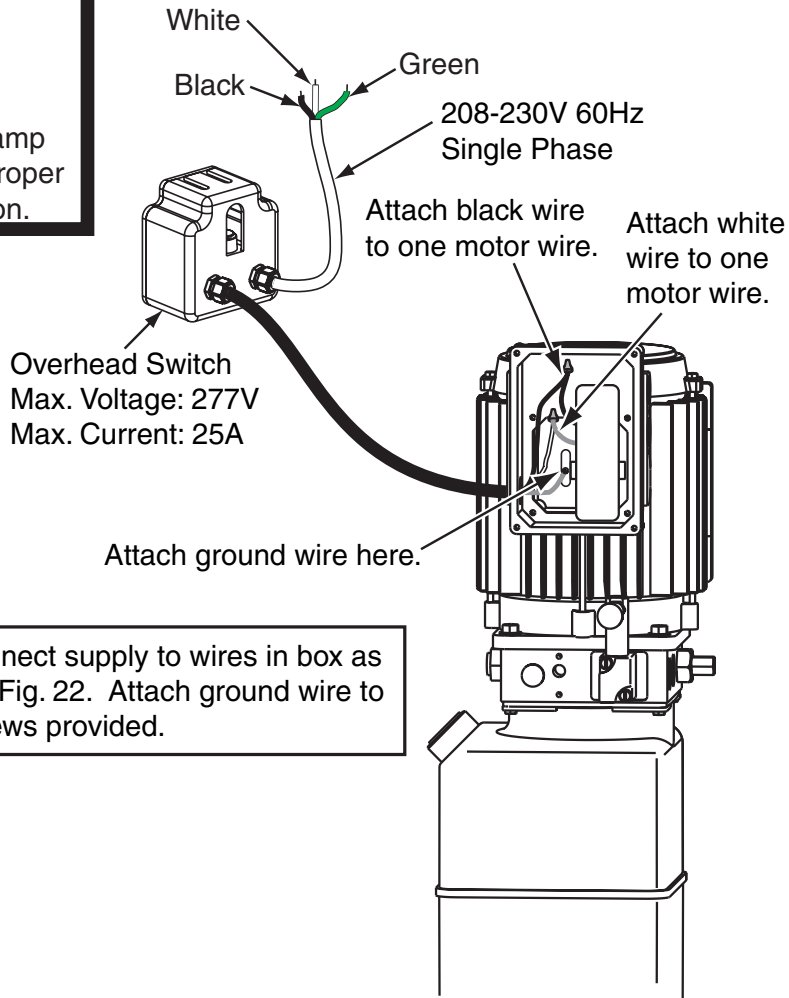

Connect supply to wires in box as per Fig. 22. Attach ground wire to screws provided.

NOTE: Two Different Drum Switches were used please select one of the two options below. Newer model three phase lifts use the push button control box with contactor. Its instructions follow the Drum Switch instructions.

NOTES:

1. Unit not suitable for use in unusual conditions. Contact Rotary for moisture and dust environment duty unit.
2. Control Box must be field mounted to power unit.
3. Motor rotation is counter clockwise from top of motor.

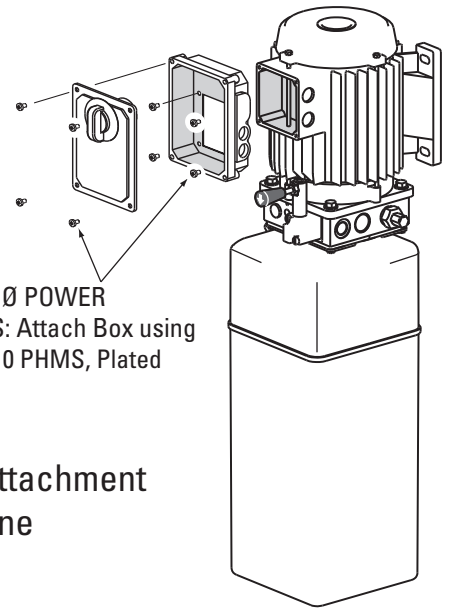
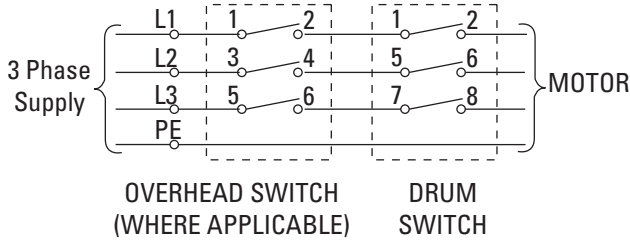

Capacitor Box Attachment Option One

Fig. 22

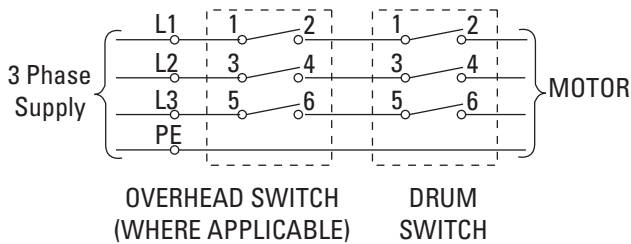
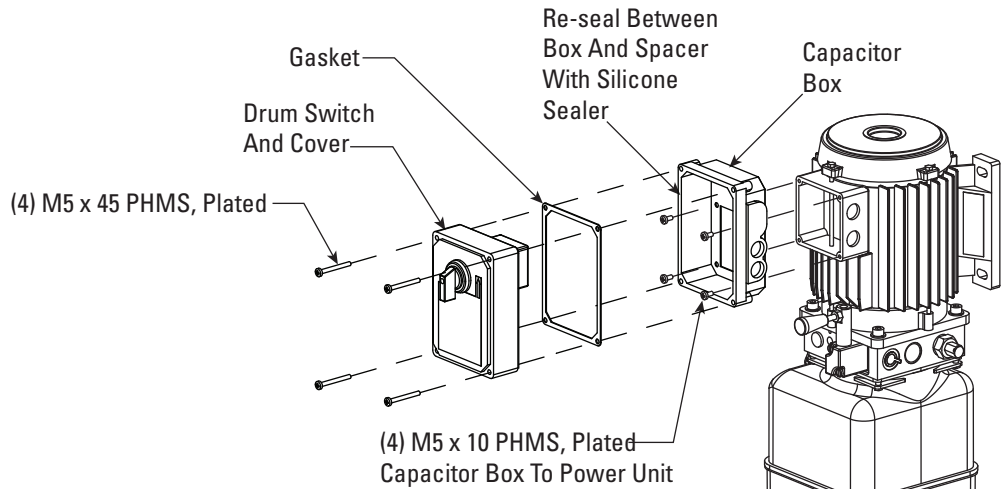

Capacitor Box Attachment Option Two

Three Phase Power Unit

MOTOR OPERATING DATA TABLE - THREE PHASE	
LINE VOLTAGE	RUNNING MOTOR VOLTAGE RANGE
208-240V 50/60Hz.	197-253V
400V 50Hz.	360-440V
440-480V 50/60Hz.	396V-528V
575V 60Hz.	518V-632V

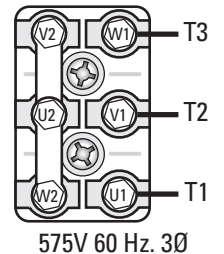
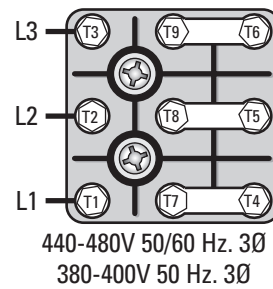
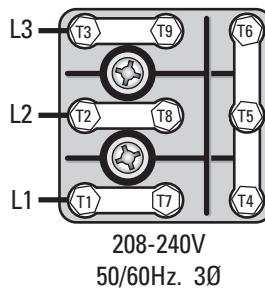

15. 3Ø Control Box Installation:

- A) Attach Mounting Bracket on column, as shown in Fig. 22a, using (1) 5/16" -18NC x 1/2" Socket Head Counter Sunk Machine Screw, (2) 5/16" -18NC x 1/2" HHCS, and (2) 5/16" Flat Washers.
- B) Attach Control Box to Bracket using (4) 1/4" -20NC x 1/2" HHCS, (4) 1/4" Flat Washers, and (4) 1/4" Star Washers.
- C) Route cord through strain relief on motor and connect per table on the bottom of page 13.

3Ø POWER UNIT

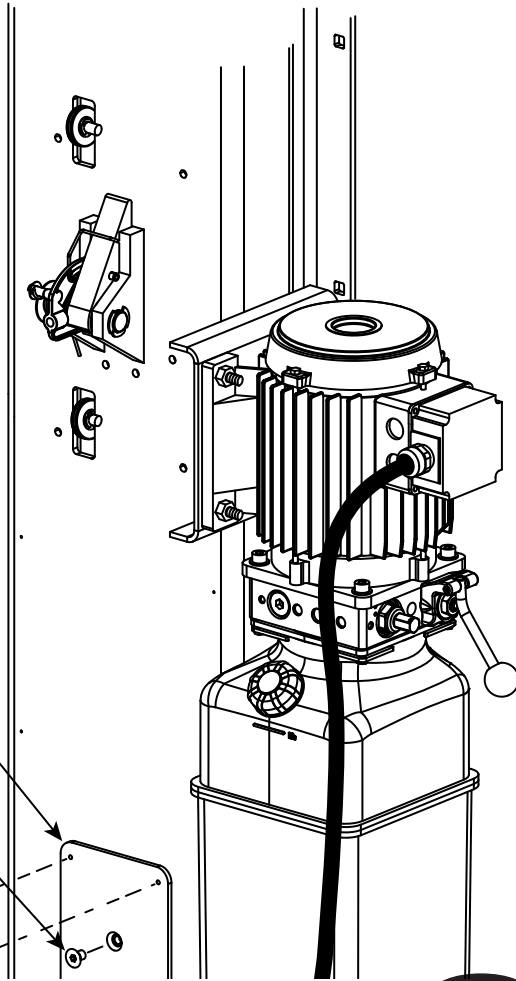

Fig. 22a

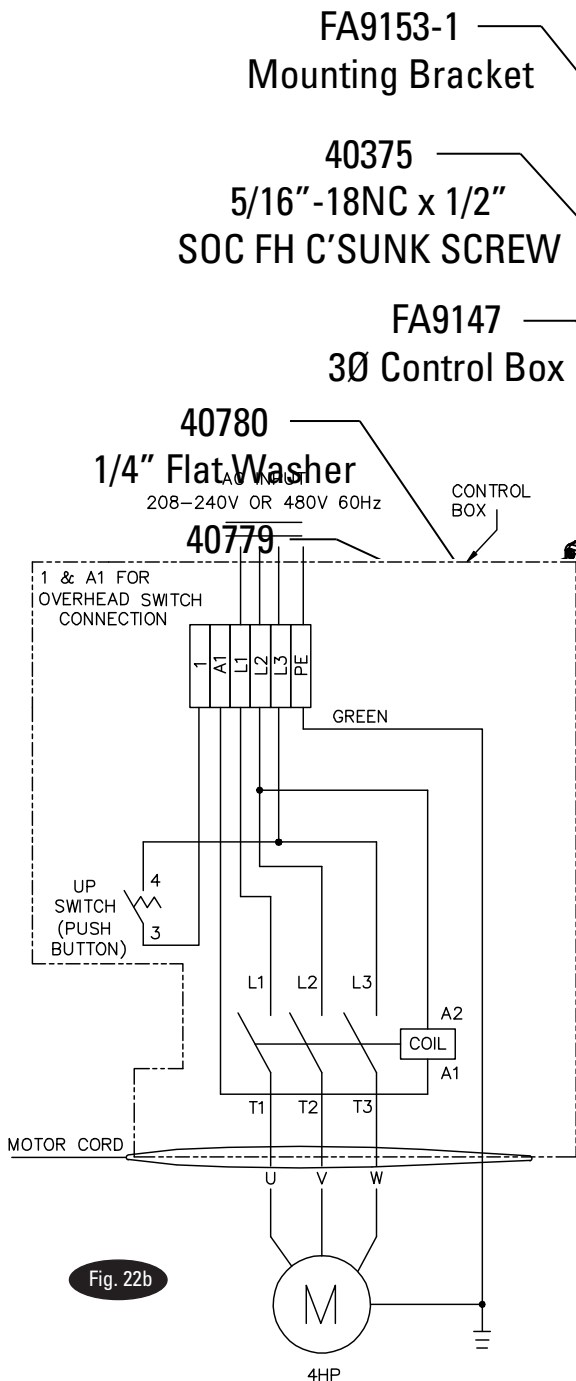
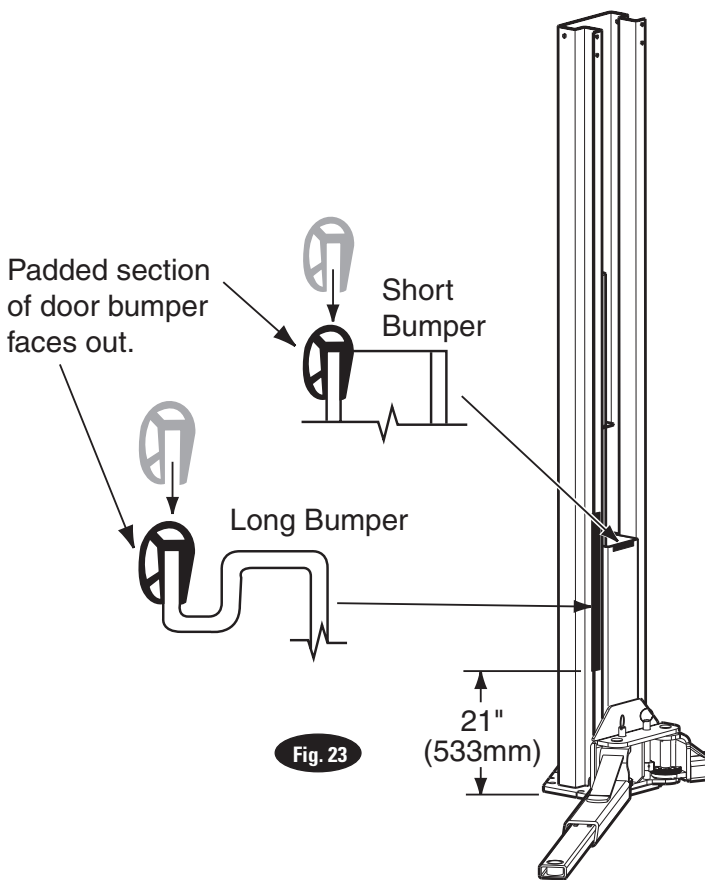
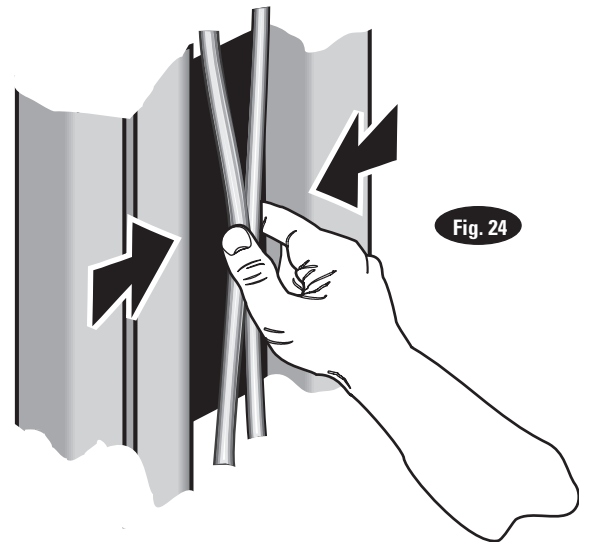

Fig. 22b

16. Oil Filling & Bleeding: Use Dexron III ATF, or Hydraulic Fluid that meets ISO 32 specifications. Remove fill-breather cap, Fig. 10. Pour in (8) quarts of fluid. Start unit, raise lift about 2 ft. Open cylinder bleeders approximately 2 turns, Fig. 12.

Close bleeders when fluid streams. Torque values for the bleeders are 15 ft. lb. minimum and 20 ft lb. maximum. Fully lower lift. Add more fluid until it reaches the MIN _____ mark on the tank. Replace fill-breather cap.

CAUTION If fill-breather cap is lost or broken, order replacement. Reservoir must be vented.



17. Overhead switch: Check overhead switch assembly to assure that switch bar is depressing switch plunger sufficiently to actuate the switch. The overhead switch is wired normally open, see Fig. 21, Fig. 22, and Fig. 22b. Lift will not operate until weight of switch bar is depressing switch plunger. Verify that Power Unit stops working when switch bar is raised, and re-starts when the bar is released.

18. Superstructure installation: If you removed arms from beginning steps, reinstall them now.

19. Door Bumper Installation:

- A) Press long bumper on column edge, Fig. 23.
- B) Press short bumper on top edge of carriage tube, Fig. 23.

20. Latch Cable Adjustment:

- A) Check to make sure the latch will properly engage and disengage. **Slowly** release the latch handle. A 1/8" gap between the top of the latch dog and the column is allowable.
- B) When raising, listen to latches to be sure that both latch dogs fall into latch slots. If they do not, loosen clamp and adjust tension as necessary.
- C) Install left latch cover using 5/16-18NC x 3/8" lg PHMS.

21. Pressure Test: Run lift to full rise and keep motor running for 5 seconds. Stop and check all hose connections. Tighten or reseal if required. Repeat air bleeding of cylinders.

22. Equalizer Cable Adjustment: Raise lift to check equalizer cable tension. Below carriage, grasp adjacent cables between thumb and forefinger, with about 15 lbs. effort you should just pull the cables together, Fig. 24. Adjust at upper tie-offs Fig. 15.

23. Latch Release Decal: Install latch release decal on cover above latch release handle, Fig. 25.

24. Pinch Point Decal Location: Install enclosed pinch point decals. Place (1) decal on each column, Fig. 26. Decals should be a minimum of 8" from the bottom of decal to the ground.

25. Wheel Spotting Dish: Position wheel spotting dish as illustrated in Fig. 1a. Drill (2) 3/8" holes 2-1/2" deep in concrete floor using holes in wheel spotting dish as guide. Drive both anchors, provided, into concrete to secure dish, Fig. 27.

26. Upon completion of the assembly of the lift, the lift is to be operated to assure proper function. Observe for locks operating in all locking positions, each side lifts equally, hydraulics do not leak, all electrical controls function as labeled, all pneumatics are functional and leak free, ramps rotate freely (if applicable), and proper clearances with all items in bay have been maintained.

Operate the lift with a typical vehicle and observe to assure the same items for proper functioning.

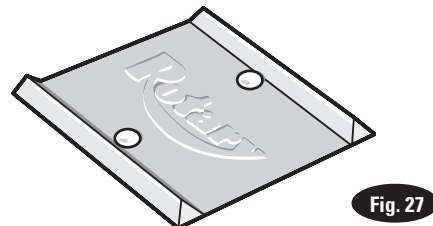
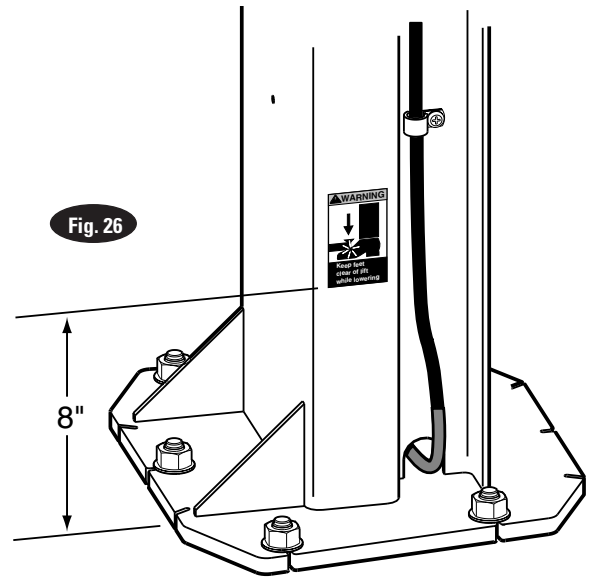
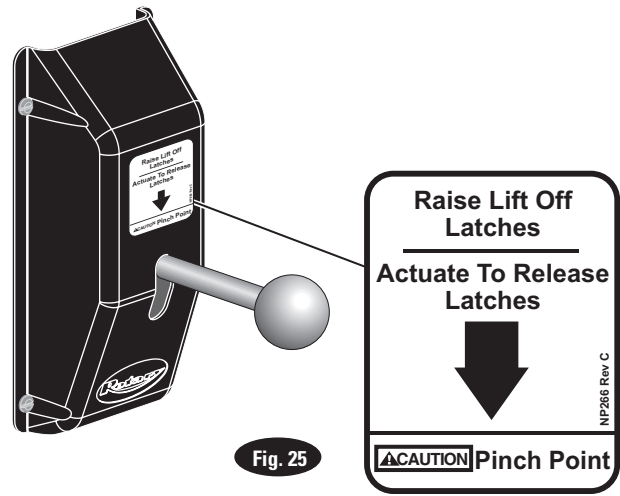

NOTES

NOTES

Installer: Please return this booklet to literature package, and give to lift owner/operator.

Thank You

Trained Operators and Regular Maintenance Ensures Satisfactory Performance of Your Rotary Lift.

Contact Your Nearest Authorized Rotary Parts Distributor for Genuine Rotary Replacement Parts. See Literature Package for Parts Breakdown.

Rotary World Headquarters
2700 Lanier Drive
Madison, IN 47250, USA
www.rotarylif.com

North America Contact Information

Tech. Support:
p 800.445.5438
f 800.578.5438
e userlink@rotarylif.com
Sales: p 800.640.5438
f 800.578.5438
e userlink@rotarylif.com

World Wide Contact Information

World Headquarters/USA: 1.812.273.1622
Canada: 1.905.812.9920
European Headquarters/Germany: +49.771.9233.0
United Kingdom: +44.178.747.7711
Australasia: +60.3.7660.0285
Latin America / Caribbean: +54.3488.431.608
Middle East / Northern Africa: +49.771.9233.0

© Vehicle Service GroupSM

Printed in U.S.A., All Rights Reserved. Unless otherwise indicated, ROTARY, and all other trademarks are property of Dover Corporation and its affiliates.

